

ROBE

ROBIN[®] LEDBeam 150

ROBIN[®] LEDBeam 150Q

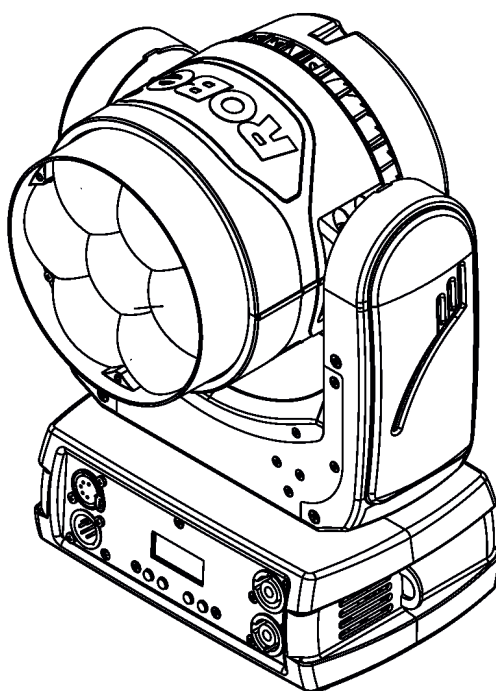

ROBE
Innovative
Technology

QR code for user manual



USER MANUAL

ROBE[®] lighting s.r.o. • Czech Republic • www.robe.cz

Version 2.1

ROBIN LEDBeam 150

ROBIN LEDBeam 150Q

Table of contents

1. Safety instructions	3
2. Fixture exterior view	5
3. Installation	6
3.1 Connection to the mains	6
3.2 Rigging the fixture	7
3.3 Eggcrate installation.....	8
3.4 Diffuser 2° installation	9
3.5 Ceiling mount kit installation.....	10
3.6 DMX-512 connection.....	11
3.7. Wireless DMX operation	12
4. Control menu map	13
5. Control menu	15
5.1 Addressing (DMXA).....	15
5.2 Fixture information (Info).....	15
5.3 Personality (Pers).....	16
5.4 Manual Control (Manual).....	17
5.5 Test program (Test Prg).....	17
5.6 Stand-alone (St Alone).....	17
5.7 Reset.....	18
5.8 Special functions (Special).....	18
6. RDM	20
7. Error and information messages	21
8. Technical Specifications	22
9. Maintenance and cleaning	25
9.1 Replacing fuse	26
10. Photometric diagrams	27
11. ChangeLog	33

**FOR YOUR OWN SAFETY, PLEASE READ THIS USER MANUAL CAREFULLY
BEFORE POWERING OR INSTALLING YOUR ROBIN LEDBeam 150 !**

Save it for future reference.

This device has left our premises in absolutely perfect condition. In order to maintain this condition and to ensure a safe operation, it is absolutely necessary for the user to follow the safety instructions and warning notes written in this manual.

The manufacturer will not accept liability for any resulting damages caused by the non-observance of this manual or any unauthorized modification to the device.

Please consider that damages caused by manual modifications to the device are not subject to warranty.

The ROBIN LEDBeam 150 was designed for indoor use and it is intended for professional application only. It is not for household use.

1. Safety instructions

DANGEROUS VOLTAGE CONSTITUTING A RISK OF ELECTRIC SHOCK IS PRESENT WITHIN THIS UNIT!

Make sure that the available voltage is not higher than stated on the rear panel of the fixture. This fixture should be operated only from the type of power source indicated on the marking label. If you are not sure of the type of power supplied, consult your authorized distributor or local power company.

Always disconnect the fixture from AC power before cleaning, removing or installing any part of the fixture.

The power plug has to be accessible after installing the fixture. Do not overload wall outlets and extension cords as this can result in fire or electric shock.

Do not allow anything to rest on the power cord. Do not locate this fixture where the cord may be damaged by persons walking on it.

Make sure that the power cord is never crimped or damaged by sharp edges. Check the fixture and the power cord from time to time.

Refer servicing to qualified service personnel.

This fixture falls under protection class I. Therefore this fixture has to be connected to a mains socket outlet with a protective earthing connection.

Do not connect this fixture to a dimmer pack.

**Warning! Risk Group 2 LED product according to EN 62471.
LED light emission. Risk of eye injury.
Do not look straight at the fixture's LED source during operation. The intense light beam may damage your eyes. Sensitive persons may suffer an epileptic shock.
Provide advance notice that strobe lighting is in use.**

**Do not view the light output with optical instruments or any device that may concentrate the beam.
The light source contains blue LEDs.**

If the fixture has been exposed to drastic temperature fluctuation (e.g. after transportation), do not switch it on immediately. The arising condensation water might damage your device. Leave the device switched off until it has reached room temperature.

Avoid brute force when installing or operating the fixture.

This fixture was designed for indoor use only, do not expose this unit to rain or use near water.

When choosing the installation spot, please make sure that the fixture is not exposed to extreme heat, moisture or dust.

Do not block the lens array with any object when the fixture is under operation.

The cooling openings in head and base of the fixture should never be covered with cloth or other materials, and never must be blocked.

This fixture should not be placed in a built-in installation unless proper ventilation is provided.

Only operate the fixture after having checked that the housing is firmly closed and all screws are tightly fastened.

Always use a secondary safety wire for overhead installation of the fixture.

Make sure that the area below the installation place is blocked when rigging, derigging or servicing the fixture.

The fixture becomes hot during operation. Allow the fixture to cool approximately 15 minutes prior to manipulate with it.

Operate the fixture only after having familiarized with its functions. Do not permit operation by persons not qualified for operating the fixture. Most damages are the result of unprofessional operation!

Please use the original packaging if the fixture is to be transported.

Please consider that unauthorized modifications on the fixture are forbidden due to safety reasons!

If this device will be operated in any way different to the one described in this manual, the product may suffer damages and the guarantee becomes void. Furthermore, any other operation may lead to dangers like short-circuit, burns, electric shock, crash etc.

Potential foggy front lens array does not influence function of the fixture and does not subject to complaint.

To avoid damage of an internal optical system of the fixture, never let the sunlight (or other light source) lights directly to the lens array, even when the fixture is not working

Potential colour non-uniformity of the front lens array may occur, it does not influence colour output from the fixture and is not considered a fault.

2. Fixture exterior view

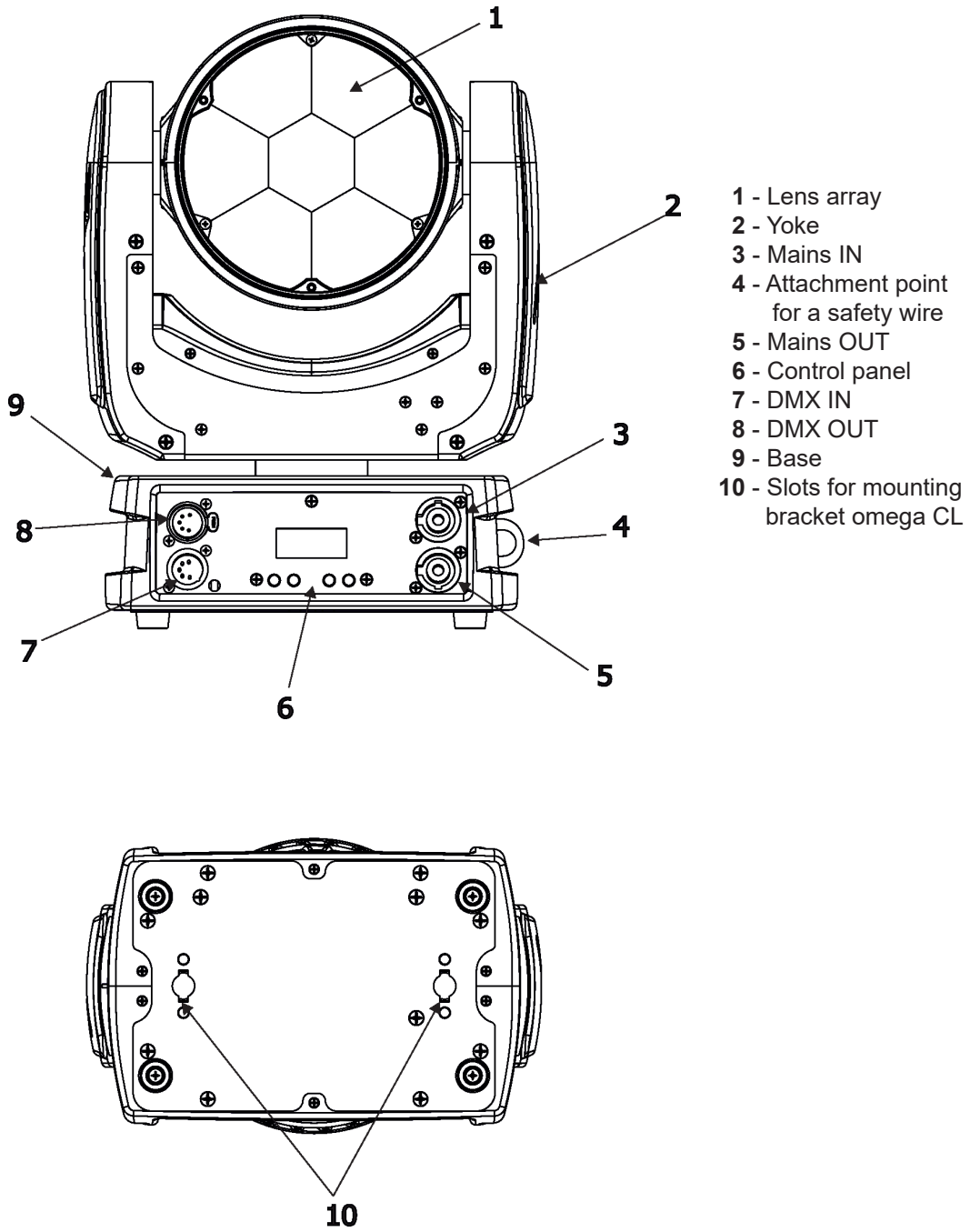

3. Installation



Fixtures must be installed by a qualified electrician in accordance with all national and local electrical and construction codes and regulations.

3.1 Connection to the mains

For protection from electric shock, the fixture must be earthed!

The ROBIN LEDBeam 150 is equipped with auto-switching power supply that automatically adjusts to any 50-60Hz AC power source from 100-240 Volts.

If you install a cord cap on the power cable to allow connection to power outlets, install a grounding-type (earthed) plug, following the plug manufacturer's instructions.

If you have any doubts about proper installation, consult a qualified electrician.

Core (EU)	Core (US)	Connection	Plug Terminal Marking
Brown	Black	Live	L
Light blue	White	Neutral	N
Yellow/Green	Green	Earth	

The device falls under class one and must be earthed (grounded)!

Design of the ROBIN LEDBeam 150 allows to connect several fixtures to AC mains power in one interconnected daisy chain using power input and throughput connectors. Needed daisy chain cords are stated in the chapter "Technical specifications"

The max. number of connected fixtures depends on the AC mains power voltage:

CE:

15 fixtures at power supply= 230V

13 fixtures at power supply= 208V

7 fixtures at power supply= 120V

ETL:

9 fixtures at power supply= 230V

8 fixtures at power supply= 208V

4 fixtures at power supply= 120V

Actual numbers of fixtures may differ from values stated above as you have to take into account the length of supply cables, circuit breaker etc. at projecting of the fixtures installation Do not overload the supply line and the connecting leads.

Do not overload the supply line and the connecting leads.

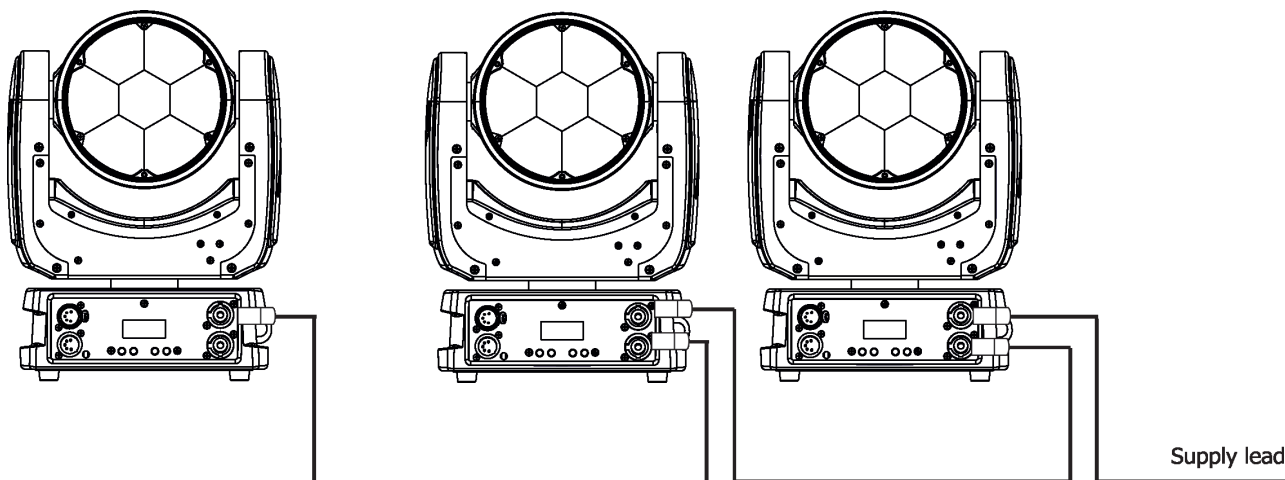

Wiring and connection work must be carried out by qualified staff!

3.2 Rigging the fixture

The installation of the fixture has to be built and constructed in a way that it can hold 10 times the weight for 1 hour without any harming deformation.

The installation must always be secured with a secondary safety attachment, e.g. an appropriate catch net. This secondary safety attachment must be constructed in a way that no part of the installation can fall down if the main attachment fails.

When rigging, derigging or servicing the fixture staying in the area below the installation place, on bridges, under high working places and other endangered areas is forbidden.

The operator has to make sure that safety-relating and machine-technical installations are approved by an expert before taking into operation for the first time and after changes before taking into operation another time.

The operator has to make sure that safety-relating and machine-technical installations are approved by an expert after every four year in the course of an acceptance test.

The operator has to make sure that safety-relating and machine-technical installations are approved by a skilled person once a year.

The fixture should be installed outside areas where persons may walk by or be seated.

IMPORTANT! OVERHEAD RIGGING REQUIRES EXTENSIVE EXPERIENCE, including (but not limited to) calculating working load limits, installation material being used, and periodic safety inspection of all installation material and the projector. If you lack these qualifications, do not attempt the installation yourself, but instead use a professional structural rigger. Improper installation can result in bodily injury or damage to property. The fixture has to be installed out of the reach of people.

If the fixture shall be lowered from the ceiling or high joists, professional trussing systems have to be used. The fixture must never be fixed swinging freely in the room.

Caution: Fixture may cause severe injuries when crashing down! If you have doubts concerning the safety of a possible installation, do not install the moving head!

Before rigging make sure that the installation area can hold a minimum point load of 10 times the fixture's weight.

When installing the device, make sure there is no highly inflammable material (decoration articles, etc.) in a distance of min. 0.4 m.

CAUTION!
Use an appropriate clamp to rig the fixture on the truss.
Follow the instructions mentioned at the bottom of the base.
Make sure that the device is fixed properly! Ensure that the structure (truss) to which you are attaching the fixtures is secure.

The fixture can be placed directly on the stage floor or rigged on a truss without altering its operation characteristics .

For securing the fixture to the truss, install a safety wire which can hold at least 10 times the weight of the fixture. Use only the safety wire with a snap hook with screw lock gate. Fasten the safety cable in the attachment point and around the truss as shown on the picture below.

Rigging via omega bracket:

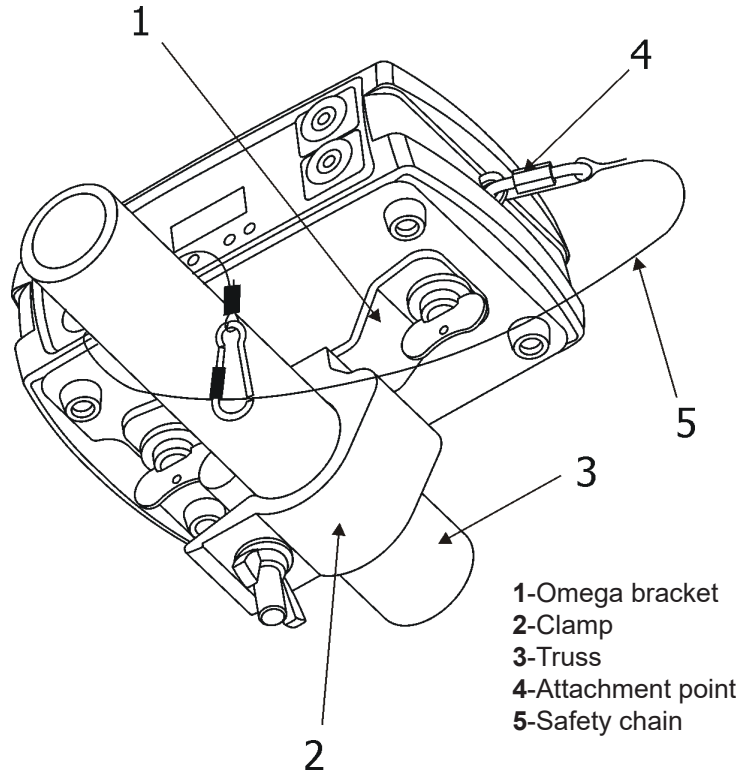

When installing fixtures side-by-side, avoid illuminating one fixture with another!

3.3 Eggcrate installation

Disconnect the fixture from mains before installing the eggcrate .

Screw the eggcrate (1) on the lens array module via the three screws (2).

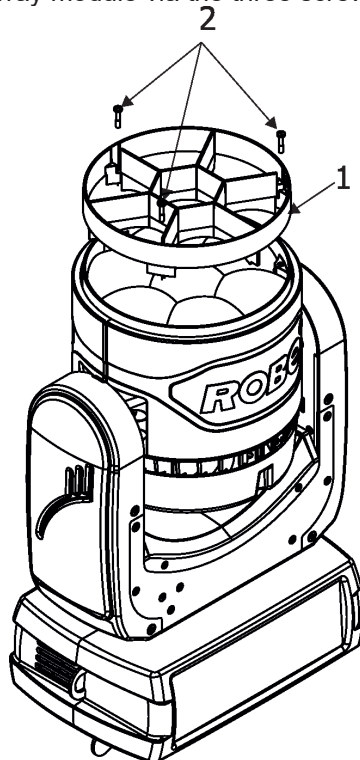

3.4 Diffuser 2° installation

Disconnect the fixture from mains before installing the diffuser.

1. Unscrew three screws (1) from fixture head and remove the plastic lens (2).
2. Place the diffuser 2° (3) to the fixture head, glossy side towards LEDs (correctly aim apertures (4) for screws).
3. Screw the diffuser 2° (3) back to the head by means of the three screws (1)

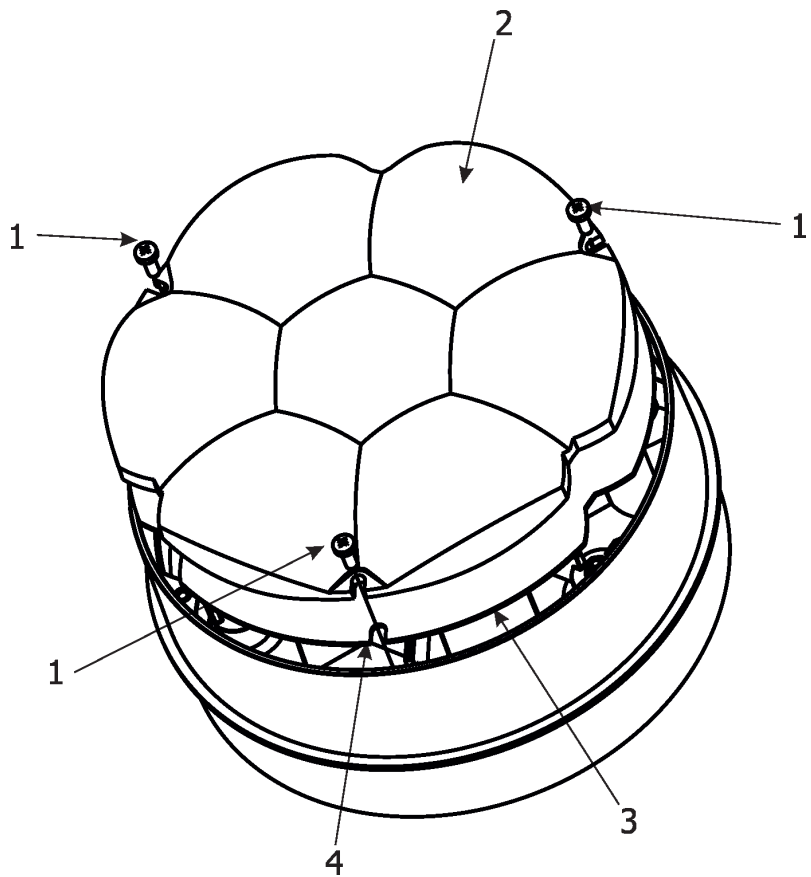

Warning
Installation of the Diffuser 2° is one-time matter as the screws (1) are screwed into the plastic.
You cannot install and uninstall the Diffuser 2° several times.

3.5 Ceiling mount kit installation

The ceiling mount kit (optional) allows you to fasten the Robin LEDBeam 150 directly on the ceiling or the wall. The ceiling mount kit includes mounting plate and two quick-lock fasteners.

The ceiling (wall) intended for installation of the fixture(s) must safely hold weight of the fixture(s) placed on it.

Ceiling mount kit installation

1. Insert two quick-lock fasteners (1) to the openings (2) in the fixture base and tighten them fully clockwise.
2. Fasten the mounting plate (3) on the non-flammable flat surface (ceiling or the wall) by means of the four holes (4) of diameter of 7.5mm. Type and length of screws choose according to the material of the ceiling (wall).
3. Insert the LEDBeam 150 into openings (5) in the mounting plate and move it in direction as shown on the picture below until securing blades (8) snap into grooves in the quick-lock fasteners.
4. Check the LEDBeam 150 is securely fastened in the mounting plate.
5. For securing the fixture to the mounting plate, install a safety wire (7) which can hold at least 10 times the weight of the fixture. Use only the safety wire with a snap hook with screw lock gate. Fasten the safety wire in the attachment point (6) of the mounting plate and in the attachment point (9) of the LEDBeam 150 base.

Note: to remove the LEDBeam 150 from the mounting plate (3), put both securing blades (8) up at the same time and slide the LEDBeam 150 out from the mounting plate (3).

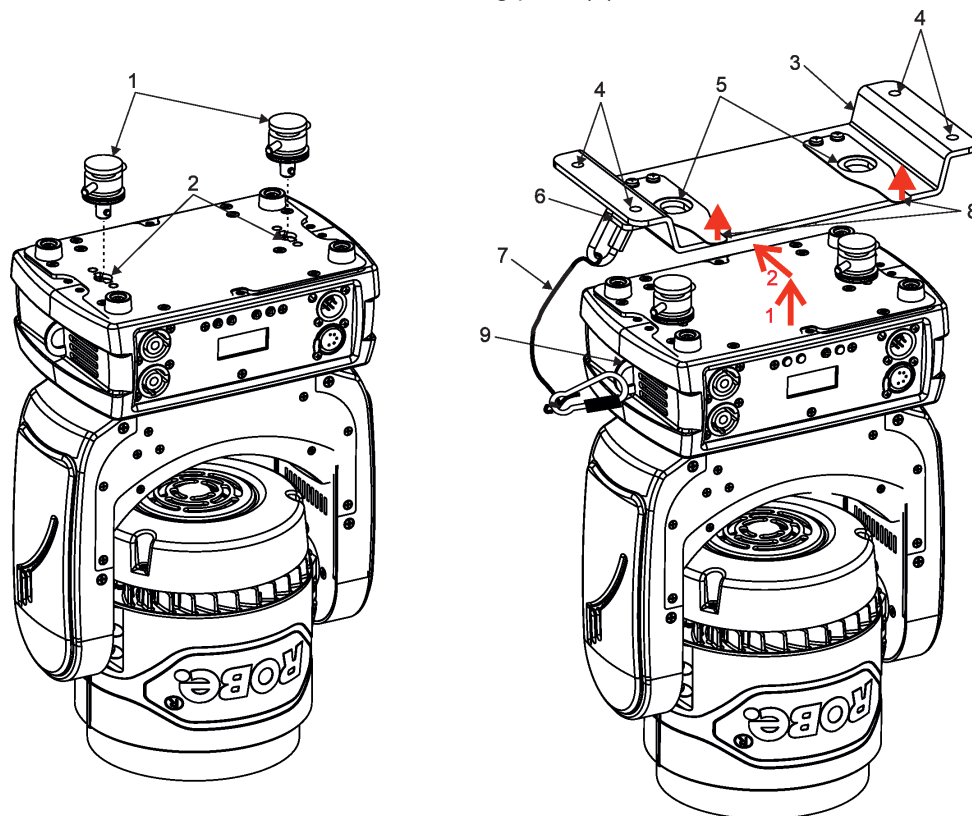

Important. In case the fixture has to be fastened on the wall, the mounting plate must be oriented by securing blades (8) up (towards the ceiling) as shown on the picture below.

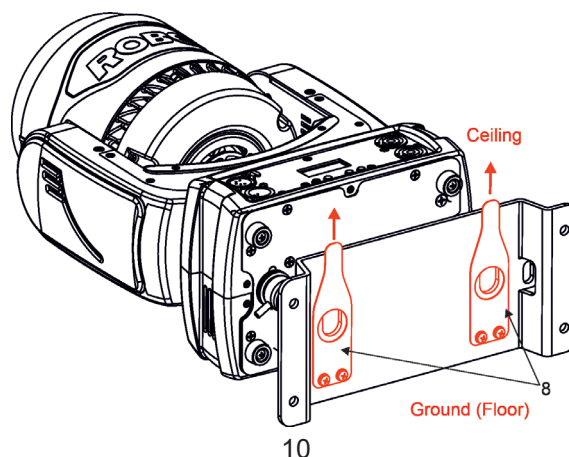

3.6 DMX-512 connection

The fixture is equipped with 5-pin XLR sockets for DMX input and output. Only use a shielded twisted-pair cable designed for RS-485 and 5-pin XLR-plugs and connectors in order to connect the controller with the fixture or one fixture with another.

DMX output

XLR socket:



- 1 - Shield
- 2 - Signal (-)
- 3 - Signal (+)
- 4 - Used for wireless DMX
- 5 - Used for wireless DMX

DMX input

XLR plug:



- 1 - Shield
- 2 - Signal (-)
- 3 - Signal (+)
- 4 - Used for wireless DMX
- 5 - Used for wireless DMX

If you are using the standard DMX controllers, you can connect the DMX output of the controller directly with the DMX input of the first fixture in the DMX-chain. If you wish to connect DMX-controllers with other XLR-outputs, you need to use adapter-cables.

Building a serial DMX-chain:

Connect the DMX-output of the first fixture in the DMX-chain with the DMX-input of the next fixture. Always connect one output with the input of the next fixture until all fixtures are connected. Up to 32 fixtures can be interconnected.

Caution: At the last fixture, the DMX-cable has to be terminated with a terminator. Solder a 120 Ω resistor between Signal (-) and Signal (+) into a 5-pin XLR-plug and plug it in the DMX-output of the last fixture.

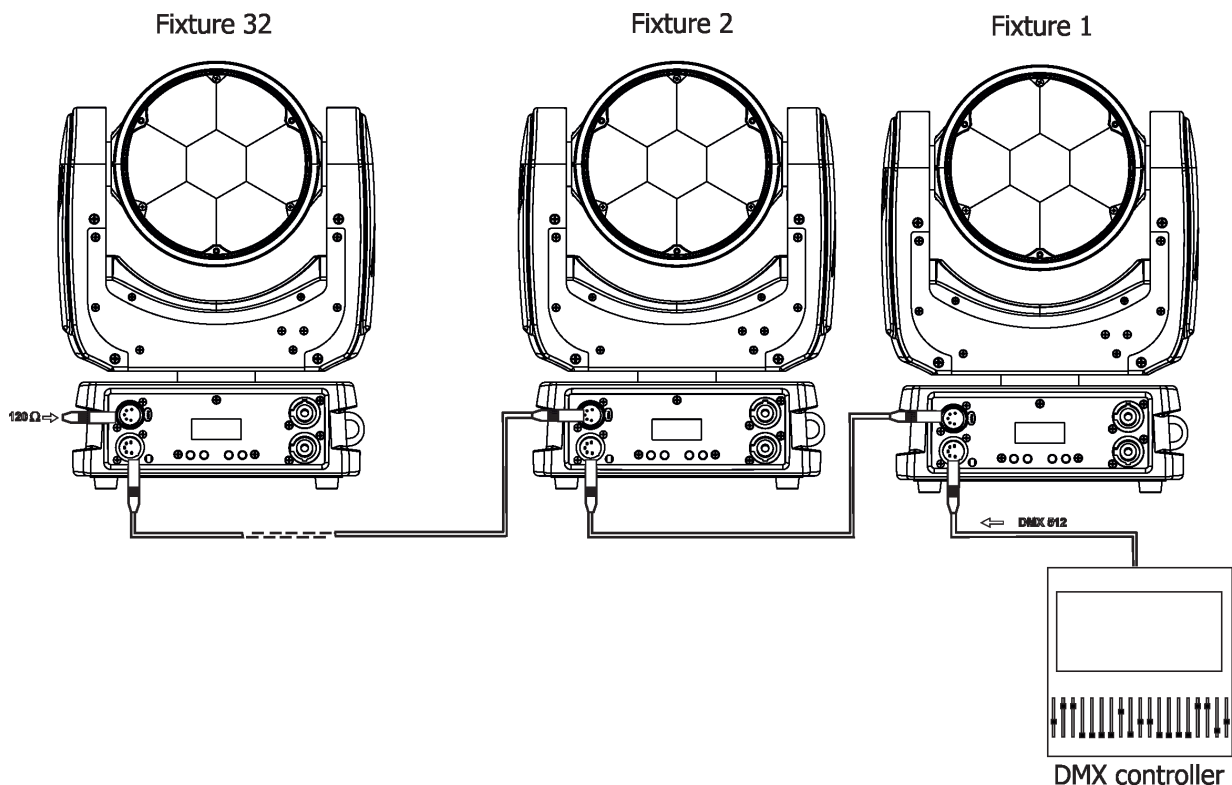

3.7. Wireless DMX operation

The external ROBE Wireless CRMX Dongle allows receiving wireless DMX. This device is equipped with the Lumen Radio CRMX module and antenna for receiving DMX signal. CRMX module operates on the 2.4 GHz band.

ROBE Wireless CRMX Dongle

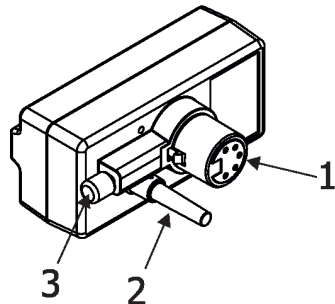

- 1 - 5-pin XLR (female)
- 2 - Locating pin
- 3 - Lock

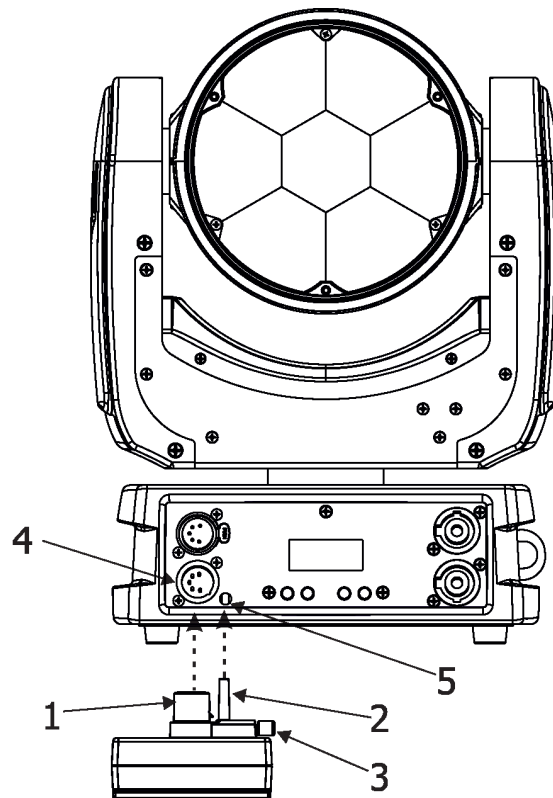

Push in the 5-pin XLR plug (1) into 5-pin XLR socket (4) and simultaneously locating pin (2) into hole (5) in the fixture. In this way the wireless DMX module is connected with the fixture.

NOTE: when you disconnect the DMX wireless module from fixture, press and hold lock (5) during getting the wireless module out.

To link the fixture with DMX transmitter.

The fixture can be only linked with the transmitter by running the link procedure at DMX transmitter . After linking , the level of DMX signal (0-100 %) is displayed in the menu item “Stat” (Special -->Wireless -->Stat).

To unlink the fixture from DMX transmitter.

The fixture can be unlinked from receiver via the menu item “ Unlink” (Special-->Wireless -->Unlink.).

4. Control menu map

Default settings=**Bold print**

Level 1	Level 2	Level 3	Level 4	Level 5	Level 6	Level 7
DMXA	Set DMXA	001-512				
	DMX Pres	Mode 1				
		Mode 2				
Info	POn Time	Total				
		Reset				
	DMX In	Pan	0-255			
		:				
		Dimm F	0-255			
	Hea Temp	Current				
		Highest				
		High Res				
	Sw Ver	IC-1				
		IC-2				
		IC-3				
Pers						
	DMX Pres	Mode 1				
		Mode 2				
	Pan Rev	On, Off				
	Tilt Rev	On, Off				
	P/T Mode	Speed				
		Time				
	P/T Feed	On, Off				
	Display	Turn				
		On/Off T	On, Off			
		Contrast	0-100%			
		Backlight	0-100%			
	BLC DMC	On, Off				
	BLC P/T	On, Off				
	Mic Sens	0... 10 ...19				
	Fans	Auto , High, Quiet				
	C Mix M	RGBW , CMY				
	White P	On, Off				
	Dimmer C	Square , Linear				
	LED Freq	Stand				
		High				
	LED Fadj	-06,-05..00..05, 06				
	Temp Uni	°C , °F				
	I Ef Pos	Pan				
		:				
		Dim F				
		Store				
	Defaults					
Manual	Pan	0-255				
	:					
	Dimm F	0-255				
Test Prg	Static	Pan	0-255			
		Tilt	0-255			
		Run				

Level 1	Level 2	Level 3	Level 4	Level 5	Level 6	Level 7
	Dynamic					
Sta Alone	Music T	On, Off				
	Auto Run	Off				
		Test				
		Prog 1				
		Prog 2				
		Prog 3				
	Pr Play	Test Prg				
		Prog 1				
		Prog 2				
		Prog 3				
	Pr Edit	Prog 1	Step 1	Pan		
		Prog 2	:	:		
		Prog 3	Step 40	F.Tim	0-25.5	
				S.Tim	0-25.5	
				COPY		
				Prg End	1-40	
Reset						
Special	RDM Low					
	RDM Hight					
	Wireless	Stat				
		Unlink				
	Adjust	DMX Val	Pan	0-255		
			:			
			Dimm F	0-255		
		Clalib	Cal Mech	Pan C	0-255	
				Tilt C	0-255	
				Zoom C	0-255	
				Store		
			Cal Col	Red C	0-255	
				Gre C	0-255	
				Blu C	0-255	
				Whi C	0-255	
				Store		
			Cal Load			
	Sw Upd	On, Off				

5. Control menu

The ROBIN LEDBeam 150 is equipped with 2-row LCD display which allows to set the fixture's behaviour according to your needs, obtain information on its operation, test its various parts and lastly program it, if it has to be used in a stand-alone mode.

Control panel:

[ESCAPE] button used to leave the menu without saving changes.

[NEXT] , [PREV] buttons for moving between menu items and for value adjusting.

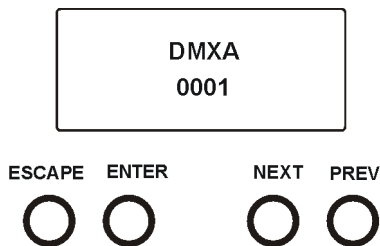

[ENTER] button used to enter the selected menu (menu item) and to confirm adjusted value.

After switching the fixture on, display shows current DMX address.

5.1 Addressing (DMXA)

Set DMXA- Use this menu item to set the DMX start address of the fixture, which is defined as the first channel from which the ROBIN LEDBeam 150 will respond to the controller.

If you set, for example, the address 23, the ROBIN LEDBeam 150 will use channels 23 - 44 for control (if Mode 1 is selected).

Please, be sure that you do not have any overlapping channels in order to control each ROBIN LEDBeam 150 correctly and independently from any other fixture on the DMX data link.

If there is no data received at the DMX input, the display will start to flash "0001" with actually stored DMX address.

DMX Pres - DMX preset. Use the menu to select desired channel mode.

Mode 1 - 22 control channels (default)

Mode 2 - 16 control channels

5.2 Fixture information (Info)

POn Time - Power on time. Select this menu to read the number of fixture operation hours.

Total - The item shows the total number of the operation hours since the ROBIN LEDBeam 150 has been fabricated.

Reset - The item shows the number of the operation hours that the ROBIN LEDBeam 150 has been powered on since the counter was last reset.

In order to reset this counter to 0, press and hold both [NEXT] and [PREV] buttons and the [Enter] button at the same time.

DMX In - DMX readout. The menu is used to read DMX values of each channel received by the fixture.

Hea Temp - Hhead Temperature. The menu shows temperature on the LED module.

Current - A current temperature of the LED module.

Highest - A maximum temperature of the the LED module since the fixture has been fabricated.

High Res - A maximum temperature of the the LED module since the counter was last reset.

In order to reset this counter, press and hold both [NEXT] and [PREV] buttons and the [Enter] button at the same time.

Sw Ver - Software versions. Select this item to read the software version of the fixture modules.

IC-1 - A pan/Tilt processor.

IC-2 - A display processor.

IC-3 - LED control processor.

5.3 Personality (Pers)

DMX Pres - DMX preset. Use the menu to select desired channel mode.

Mode 1 - 22 control channels

Mode 2 - 16 control channels

Pan Rev - Pan reverse. The item allows to invert pan movement.

Tilt Rev - Tilt reverse. The item allows to invert tilt movement.

P/T Mode - Pan and Tilt movement mode. Use this menu to set mode of the pan/tilt movement.

Speed - Both Pan and tilt will move with the same speed as adjusted at the channel 5 "Pan/Tilt speed, Pan/Tilt time".

Time - The pan and tilt will move with different speeds and they will come at the same time to the end point of their tracks (pan and tilt use their optimal speeds).

Time of the pan/tilt movement (25.5 sec. max.) is set by the channel "Pan/Tilt speed, Pan/Tilt time".

P/T Feed - Pan and Tilt Feedback. The menu item allows to return the mowing head to the required pan/tilt position after changing the position by an external force if this option is set on.

Note. The Pan/Tilt Feedback should be permanent On, the option Off is not suitable for standard operation and the head of the fixture can be damaged!

Display - Display adjusting. This menu allows you to adjust the display behaviour.

Turn - This function turns the display by 180°.

On/Off T - This function allows you to keep the display permanent on or turn it off two minutes after last pressing any button on the control panel.

Contrast - Use this function to adjust contrast of the display (0-100%).

Backlight - Use this function to adjust backlight of the display (0-100%).

BLC DMC - Blackout during movement correction. Set this option on if you wish to close light output during the time when the head goes to its correct position, which has been changed by an external force.

BLC P/T - Active blackout. The menu item allows to close light output while the pan/tilt DMX values are changing.

C Mix M - Colour mixing mode. This item allows switching into RGBW or CMY mode. In the CMY mode, the white(8bit)/white (16) bit channels are not active.

White P - White Point 8000K. If the function is on, the CTC channel allows to set desired white in range of 8000K-2700K

(0 DMX=8000K, 255 DMX=2700K). Necessary condition is , that RGBW channels have to be full or set at the same DMX values, e.g. 150.

If this function is off, the range of whites is not uniform and may be different for each fixture.

Mic Sens - Microfon sensitivity. Enter the menu if you want to adjust the microphone sensitivity (1-max., 19-min.).

Fans - Fans mode. Use the menu to set the fixture fans to the max. power ("High") ,auto-control mode ("Auto") and quiet mode ("Quiet").

Dimmer C - Dimmer curve. Use the menu to select desired dimmer curve.

Linear - a linear curve.

Square - a square law curve.

LED Freq - LEDs frequency setup. The function allows you to set the PWM (Pulse Width Modulation) output frequency of LEDs to Standard or High.

Stand - a standard frequency (300Hz), default setting.

High - a high frequency (600Hz)

LED Fadj - LEDs frequency fine adjustment. The function allows you to change the selected PWM output frequency of LEDs in 6 levels up and down around the selected frequency in the menu "LED Freq".

- 06...-01 - Frequency levels 1-6 under selected frequency.
- 00 - Selected frequency (Standard or High)
- 01...06 - Frequency levels 1-6 above selected frequency.

Temp Uni - Temperature unit. Use the menu item to change temperature unit from °C to °F.

I Ef Pos - Init effect positions. Use the menu to set all effects to the desired positions at which they will stay after switching the fixture on without DMX signal connected.

Defaults - The menu item allows to set all fixture parameters to the default (factory) values.

5.4 Manual Control (Manual)

Use the menu to control all fixture channels by means of the control panel.

5.5 Test program (Test Prg)

Use this menu to to run a special demo-test sequences without an external controller, which will show you some possibilities of using ROBIN LEDBeam 150.

Static - **Static mode**. This mode is suitable for projections on the wall, ceiling or ground without any head movement.

Dynamic - **Dynamic mode**. This mode uses all ROBIN LEDBeam 150 functions including pan/tilt movement and therefore is good for a complete introduction of the fixture.

5.6 Stand-alone (St Alone)

Music T - **Music trigger**. Select this function to enable the sound control of the running program via the built-in microphone.

Auto Run - **Presetting playback**. This function allows you to select the program which will be played in the stand-alone mode after switching the fixture on. Selected program will be played continuously in a loop.

Off - The option disables „Auto Run” function.

Test - The option will start built-in test program.

Prog 1 - The option will start user-created program 1

Prog 2 - The option will start user-created program 2

Prog 3 - The option will start user-created program 3

Pr Play - **Playing program**. Select this menu to run a user-created program in a loop.

Test Prg - The option runs built-in test program.

Prog 1 - The option runs user-created program 1

Prog 2 - The option runs user-created program 2

Prog 3 - The option runs user-created program 3

Select the program you wish and press [ENTER]. The selected program starts running. By Pressing [ENTER] again, program pauses running.

Pr Edit - **Editing program**. Select this menu to edit or create the program. The ROBIN LEDBeam 150 has one built-in program and one user-editable program up to 40 steps. Each program step has a step time - during which effects last in the current step and a fade time- during which effects move to new positions.

To edit program:

Procedure:

1. Press [NEXT] or [PREV] to select the menu "Edit" and press [ENTER].
2. Press [NEXT] or [PREV] to select the desired program step and press [ENTER] button.
3. Press [NEXT] or [PREV] to select the desired item and press [ENTER] button. Now you can edit by [NEXT] or [PREV] buttons the DMX value (0-255) for selected item:

Prg End.	a total number of the program steps (value 1-40). This value you should be set before starting of programming (e.g. if you want to create program with the 10 steps, set Prg End=10).
PAn	a coarse pan movement
PAn F	a fine pan movement
Tilt	a coarse tilt movement
Tilt F	a fine tilt movement
P/T Sp	a pan/tilt speed
Power	power/special functions

Virt C	a virtual colour wheel
Red	a red colour coarse
Red F	a red colour fine
Green	a green colour coarse
Green F	a green colour fine
Blue	a blue colour coarse
Blue F	a blue colour fine
White	a white colour
White F	a white colour fine
CTC	a colour temperature correction
C Mix C	a colour mix control
Zoom	a zoom function
Zoom F	a zoom function fine
Stro	a strobe/shutter function
Dimm	a dimmer function coarse
Dim F	a dimmer function fine
F.Tim	a fade time (0-25.5 sec)
S.Tim	a step time (0-25.5 sec)
COPY	copying the current prog. step to the next prog. step

4. Press [ENTER] button to confirm adjusted value .
5. Press [ESCAPE] button, select next prog. step, press [ENTER] button and repeat steps 3 - 5).

5.7 Reset

This option enables the ROBIN LEDBeam 150 to index all effects and return to their standard positions.

5.8 Special functions (Special)

RDM Low - This menu item shows the first part of the RDM identification code.

RDM High - This menu item shows the second part of the RDM identification code.

Wireless - **Wireless DMX information.** The menu allows to read some information about Wireless DMX operation

Stat - **Wireless status.** Use the menu to read wireless DMX status.

Unlink - use this item to unlink fixture from wireless DMX.

Adjust - **Adjustment.** The menu allows the fine adjustment of effects.

DMX Val- **DMX values.** Use the menu to set DMX values of fixture's channels.

Calib - calibration of white colour.

Cal Mech - Use this menu to calibrate pan/tilt/zoom position.

Cal Col - Use this menu to set white colour 5600K.

Calibration of the pan/tilt/zoom via the control board

1. Disconnect DMX controller from the fixture and enter the "Cal Mech" menu.
2. Use the [PREV] and [NEXT] to find "Pan C" and press [ENTER].
3. Set desired value and save it by pressing [ENTER].
4. Repeat steps 2 and 3 for "Tilt C" and "Zoom C".
5. After calibrating both effects, find item "Store" and press [ENTER]. to save all adjusted values and reset the fixture.

Calibration of the white 5600K via the control board

1. Disconnect DMX controller from the fixture , set the shutter, dimmer and RGBW channels at 255 DMX, zoom at 128 DMX and the CTC channel at DMX=64 (white 5600K). Aim the light beam on the lux meter (e.g. Minolta CL-500 A Chroma meter) which is placed cca 5m from the fixture.
2. Set the menu items Colour Mix Mode to RGBW and "White Point 8000K to On (Pers-> C Mix M -> RGBW, Pers-> White P -> On).
3. Enter the menu "Cal Col".
4. By means of the "Red C, Gre C, Blu C and Whi C" items adjust the 5600K colour temperature

as exactly as possible ($\Delta u'v' = 0$).

5. After adjusting 5600K colour temperature, select item Store and press the [ENTER] button to save all adjusted values .

Note: you can also use DMX controller for both calibrations stated above, calibration protocol is the following:

Effect	Mode 1	Mode 2
Pan-fine adjustment	channel 23	channel 17
Tilt - fine adjustment	channel 24	channel 18
Zoom -fine adjustment	channel 25	channel 19
Red - red saturation	channel 26	channel 20
Green- green saturation	channel 27	channel 21
Blue - blue saturation	channel 28	channel 22
White - white saturation	channel 29	channel 23

Cal Load - Loads default (factory) calibration.

Sw Upd - Software update. The menu item allows you to update software in the fixture via either serial or USB port of PC.

The following items are required in order to update software:

- PC running Windows or Linux or macOS
- DSU file
- Flash cable RS232/DMX, P/N13050624 (if you want to use a serial port of PC)
- Robe Universal Interface or Robe Universal interface WTX (if you want to use an USB port of PC)

After the software updating the fixture will be set to default (factory) values.

To update software in the fixture:

1. DSU file is available from Robe web site at WWW.robe.cz.

File with extension zip is intended for Windows (used and tested from XP to W10 on 32/64bit systems).

File with extension tbz is intended for Linux (used and tested on Debian and Ubuntu 32/64bit).

File with extension dmg is intended for macOS (used and tested on OSX up to Sierra) XQuartz required, install it from <https://www.xquartz.org/>

Save the download file to a folder on your computer.

In case that you use windows, extract files in the zip file (e.g. DSU_RobinLedBeam150_18041738.zip)

2. Disconnect the fixture from DMX controller.

3. If you use the flash cable RS232/DMX, connect a serial port of your computer with DMX input of the fixture by means of the cable.

If you use the Robe Universal Interface, connect a USB port of your computer with the Robe Universal Interface by means of the USB cable and DMX input of the fixture with the DMX output of the Robe Universal Interface via a DMX cable.

4. Switch the fixture to the update mode (Special --> SW Upd).

Note: If you do not want to continue in the software update, you have to switch off and on the fixture to escape from the updating mode.

We recommend to cancel all running programs on your computer before starting the software update.

5. Double-click the software uploader file (e.g. DSU_RobinLedBeam150_18041738.exe) in the extracted files. The Software Uploader program will start running.

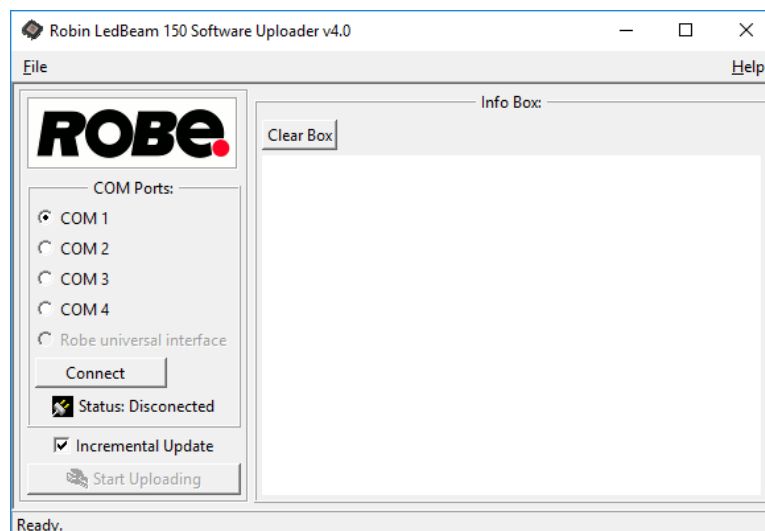

6. Select correct "COM " number if you use a Flash cable RS232/DMX or select "Robe Universal Interface 1 " if you use the Robe Universal Interface/Robe Universal Interface WTX and then click on the "Connect" button.
7. If the connection is OK, click the "Start Uploading" button to start software uploading. It will take several minutes to perform software update.
 If the option "Incremental Update" is not checked, all processors will be updated (including processors with the same software version).
 If you wish to update only processors with new version of software, check the "Incremental Update box".
 Avoid interrupting the process. Update status is being displayed in the "Info Box" window.
 When the update is finished, the line with the text "Fixture is successfully updated" will appear in this window.

In case upload process is interrupted (e.g. power loss), the fixture stays in "Updating mode" and you will have to repeat the software update again.

Another way, how to update software in the fixtures (especially large installation of fixtures) is to use the ROBE Uploader. It is a software for automatized software update of Robe fixtures. It takes advantage of RDM support).

For more information please see <https://www.robe.cz/robe-uploader/>.

6. RDM

This fixture supports RDM operation. RDM (Remote Device Management) is a bi-directional communications protocol for use in DMX512 control systems, it is the new open standard for DMX512 device configuration and status monitoring.

The RDM protocol allows data packets to be inserted into a DMX512 data stream without adversely affecting existing non-RDM equipment. By using a special „Start Code,“ and by complying with the timing specifications for DMX512, the RDM protocol allows a console or dedicated RDM controller to send commands to and receive messages from specific moving lights.

RDM allows explicit commands to be sent to a device and responses to be received from it.

The list of commands for ROBIN LEDBeam 150 is the following.

Parameter ID	Discovery command	SET command	GET command
DISC_UNIQUE_BRANCH	*		
DISC_MUTE	*		
DISC_UN_MUTE	*		
DEVICE_INFO			*
SUPPORTED_PARAMETERS			*
SOFTWARE_VERSION_LABEL			*
DMX_START_ADDRESS		*	*
IDENTIFY_DEVICE		*	*
DEVICE_MODEL_DESCRIPTION			*
MANUFACTURER_LABEL			*
DEVICE_LABEL		*	*
SENSOR_DEFINITION			*
SENSOR_VALUE			*
DISPLAY_INVERT		*	*
DISPLAY_LEVEL		*	*
PAN_INVERT		*	*
TILT_INVERT		*	*
DEVICE_RESET		*	
DMX_PERSONALITY		*	*
DMX_PERSONALITY_DESCRIPTION			*
STATUS_MESSAGES			*
STATUS_ID_DESCRIPTION			*

DEVICE_HOURS			*
PARAMETER_DESCRIPTION			*
ROBE_DMX_INPUT		*	*
ROBE_WIRELESS_UNLINK		*	

RDM model ID for the ROBIN LEDBeam 150 is 0x00db.

7. Error and information messages

Short Err

The message informs you that short circuit has occurred on the LED PCB.

Tilt Err

This message will appear after the reset of the fixture if the head's magnetic-indexing circuit malfunctions (sensor failed or magnet is missing) or the stepping motor is defective or its driving IC on the PCB. The head is not located in the default position after the reset.

8. Technical Specifications

Electrical

Power supply:.....electronic auto-ranging
Input voltage range:..... supply 100-240V, 50-60Hz
Fuse:.....T 3.15A
Max. power consumption220W (I=0.98A, power factor=0.97 at 230V)
Mains input: CE - max. 16A
 ETL - max. 10A
Mains output: CE - max. 15A
 ETL - max. 9A

Optic

Light source: 7 x high power RGBW multichip LEDs
Min LED life expectancy: 20.000 hours
RGBW/CMY colour mixing
Variable CTO 2700K-8000K

Virtual colour wheel

66 preset colours
Halogen lamp effect at whites 2700K and 3200K
Rainbow effect with in both directions with variable speed

Zoom range

3.8°-60°

Strobe

Strobe effect with variable speed (0.3 - 20Hz)
Random strobe pulse-effect with variable speed
Opening/closing pulse effect with variable speed

Dimmer

Smooth dimmer from 0 - 100 %

Pan/Tilt

Max. pan movement range: 450°
Max. tilt movement range: 228°
16 bit movement resolution
Automatic Pan/Tilt position correction
Remotely controllable speed of pan/tilt movement for easy programming

Control

2-row LCD display & 4 buttons
Readout fixture usage, receiving DMX values, temperatures, etc
Built-in analyzer for easy fault finding, error messages
Built-in demo sequences
Silent fans cooling,
Stand-alone operation
3 user editable programs, each up to 40 steps
Supported protocols: USITT DMX 512, RDM,
Support of RDM (Remote Device Management)
2 DMX modes (22, 16 control channels)

External Wireless DMX/RDM module (optional)

Compliance with USITT DMX-512 (1986 & 1990) and 512-A
Full DMX fidelity and frame integrity

Auto sensing of DMX frame rate and frame size
 <5ms DMX latency
 Operational frequency range of 2402-2480 MHz
 Producer: LumenRadio

Connection

DMX data in/out: Locking 5-pin XLR
 AC power input: Chassis connector Neutrik PowerCon, A-type, NAC3MPA
 AC power output: Chassis connector Neutrik PowerCon, B-type, NAC3MPB

Rigging

Mounting points: pair of 1/4-turn locks
 Mounting horizontally or vertically via Omega bracket

Temperatures

Maximum ambient temperature : 45° C
 Maximum housing temperature : 80° C

Distances

Min. distance from flammable surfaces: 0.4 m
 Min. distance of illuminated objects: 0.8 m

Total heat dissipation

750 BTU/h (calculated)

Weight:

5.7 kg

Dimensions (mm)

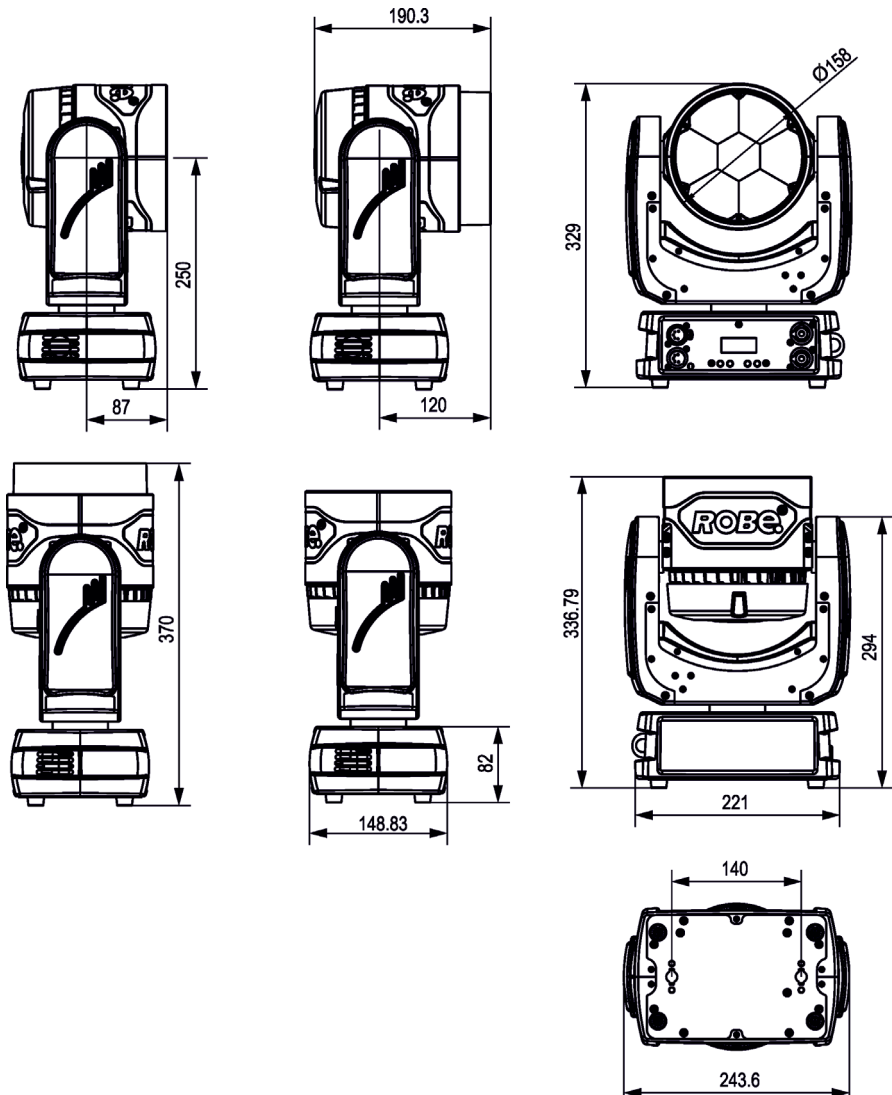

Accessories

1x Mounting bracket Omega CL assembled (P/N 99010420)

Optional accessories

- (P/N 10980127) ROBE Wireless CRMX Dongle
- (P/N1305 1731) Mains Cable PowerCon In/open ended, 2m
- (P/N 1305 1724) Mains Cable PowerCon In/Schuko, 2m
- (P/N 1305 1725) Mains Cable PowerCon In/CEE 16A, 2m
- (P/N 1305 1726) Mains Cable PowerCon In/US, 2m
- (P/N 1305 1727) Daisy Chain PowerCon In/Out, EU, 2m
- (P/N 1305 1728) Daisy Chain PowerCon In/Out, US, 2m
- (P/N 10980346) EggCrate for Robin LEDBeam 150
- (P/N 10980496) EggCrate for Robin LEDBeam 150 RAL9003 glossy
- (P/N 10980445) EggCrate for Robin LEDBeam 150, ParFect 150 white
- (P/N 10980423) Diffuser 2° for Robin LEDBeam 150
- (P/N 17030386) Doughty Trigger Clamp
- (P/N 99011963) Safety wire 35 kg
- (P/N 10981157) Ceiling Mount Kit for LEDBeam 150 black

Dimensions (mm) of the mounting plate of the Ceiling Mount Kit for Led Beam 150 FWQ.

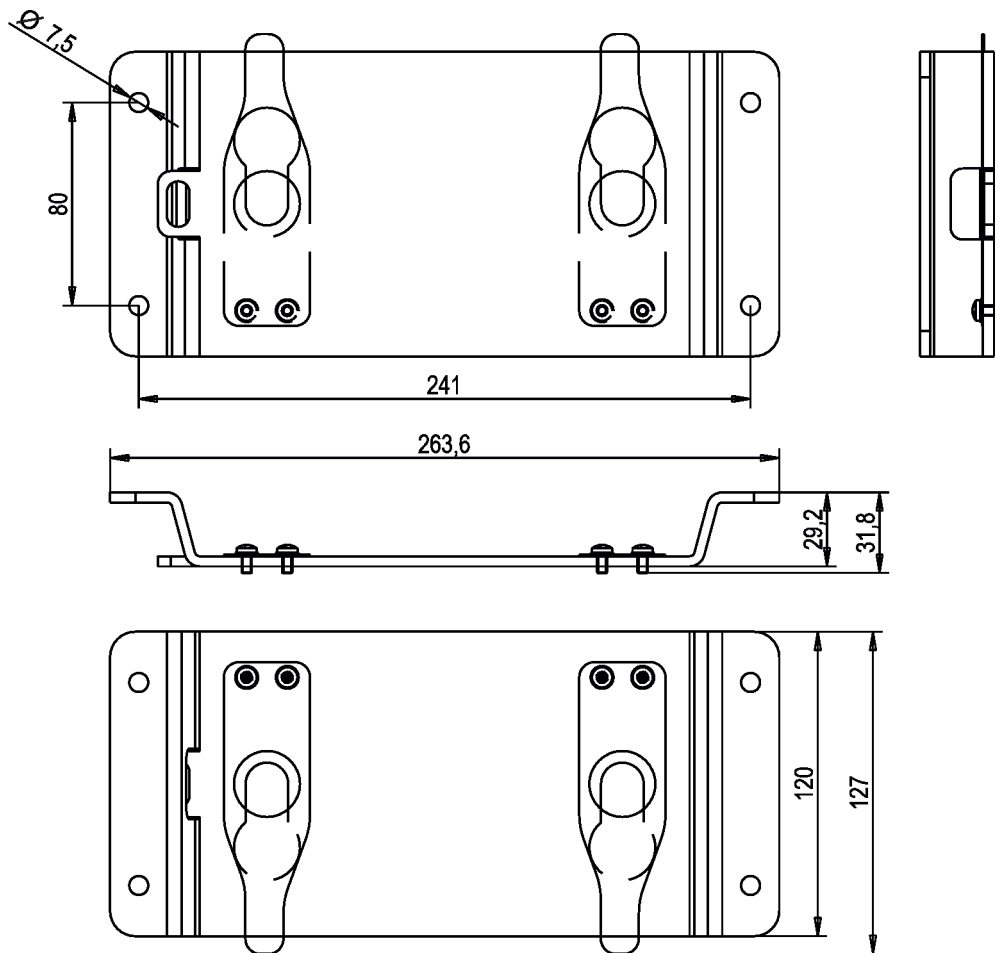

9. Maintenance and cleaning

It is absolutely essential that the fixture is kept clean and that dust, dirt and smoke-fluid residues must not build up on or within the fixture. Otherwise, the fixture's light output will be significantly reduced. Regular cleaning will not only ensure the maximum light output, but will also allow the fixture to function reliably throughout its life. A soft lint-free cloth moistened with any weak detergent solution is recommended for cleaning fixture's covers, under no circumstances should alcohol or solvents be used!

DANGER !
***Disconnect from the mains before starting any
maintenance and cleaning work***

The interior of the fixture should be cleaned at least annually using a vacuum cleaner or compressed air. The cooling fans should be cleaned at least twice a year.

Important! Never use alcohols (ethanol, methanol, isopropyl alcohol), acetone and another aggressive solvents for cleaning the front lens array.

Recommended steps for cleaning the front lens array:

1. Use low-pressure compressed air to remove coarse dust from lenses.
2. Use distilled water with weak detergent solution and lint-free small cloth for further cleaning of lenses.
3. Use an antistatic, alcohol-free screen cleaner (we recommend the Lyreco Screen Cleaner) and polish lenses until they are dry.
4. Check the lenses are dry before reapplying power.

Note: potential foggy front lens array does not influence function of the fixture and does not subject to complaint

More complicated maintenance and service operations are only to be carried out by authorized distributors.

9.1 Replacing fuse

1. Replace the fuse by a fuse of the same type and rating only.

Before replacing the fuse, unplug mains lead!

2. Remove the plastic covers of the base (3) by unscrewing 5 fastening screws (1) and (2) on each cover.

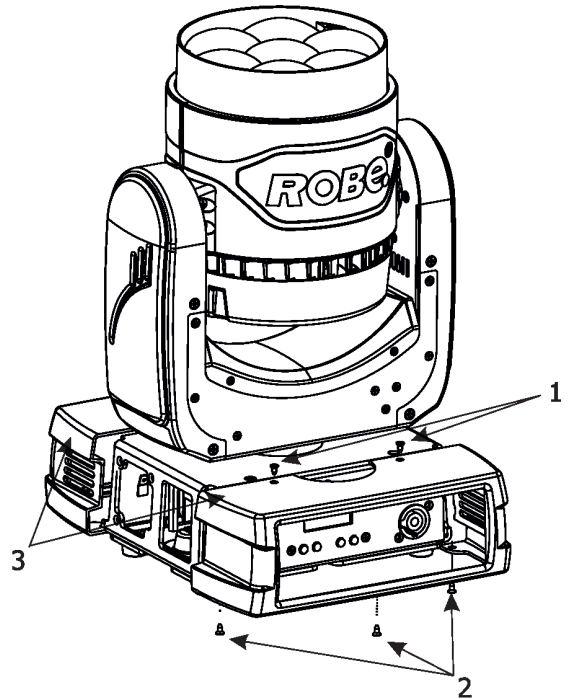

3. Unscrew four screws (4) on the top chassis (5). Lay down the fixture and unscrew four screws (6) on the bottom plate (9) to push out inside module of the base.

4. Unscrew two screws (8) on the bottom plate to remove rear panel of the fixture (7).

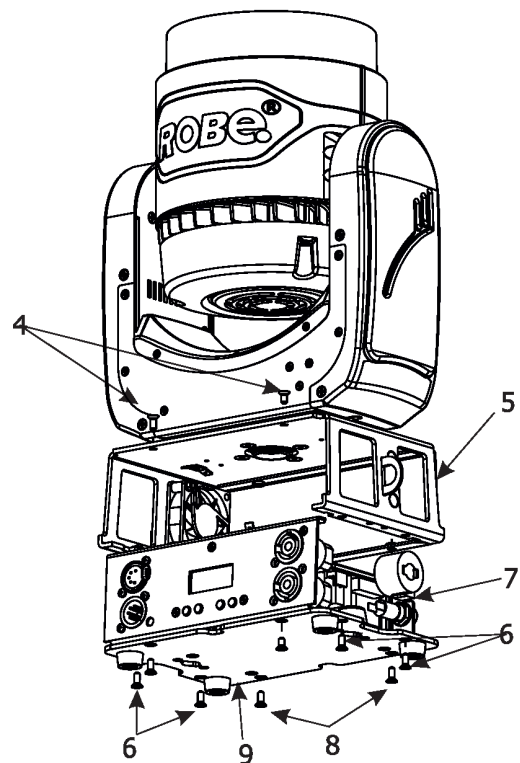

5. Now you have access for the fuse holder (10) in the inside module of the base.

6. Remove the old fuse from the fuseholder.

7. Install the new fuse into the fuseholder.

8. Assemble the base of the fixture.

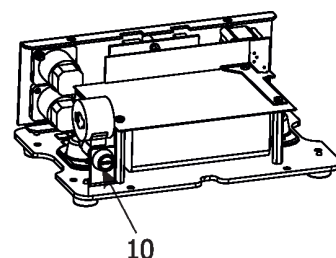

10. Photometric diagrams

Robin LED Beam 150 without diffuser 2°

Min. Zoom

Total Output: 1380 lumens

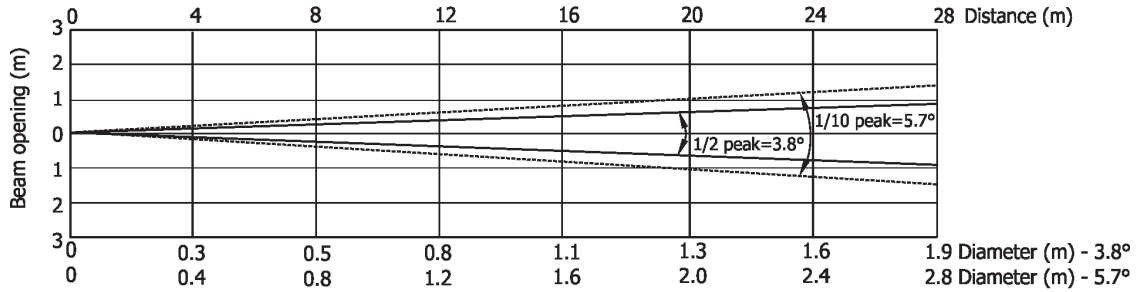

Distance (m)	4	5	8	12	16	20	24	28	
Red	3938/366	2520/234	984/92	438/41	246/23	157/15	109/10	80/8	Intensity (center) Lux/Footcandles
Green	7484/695	4790/445	1781/174	832/77	468/44	300/28	208/19	153/14	
Blue	1867/157	1080/100	422/39	187/17	105/10	68/6	47/4	34/3	
White	9531/886	6100/566	2383/221	1059/98	596/56	382/35	265/25	194/18	
R+G+B+W	19062/1771	12200/1133	4765/443	2118/197	1191/111	762/71	530/50	389/36	

Illuminance distribution

Distance=5m

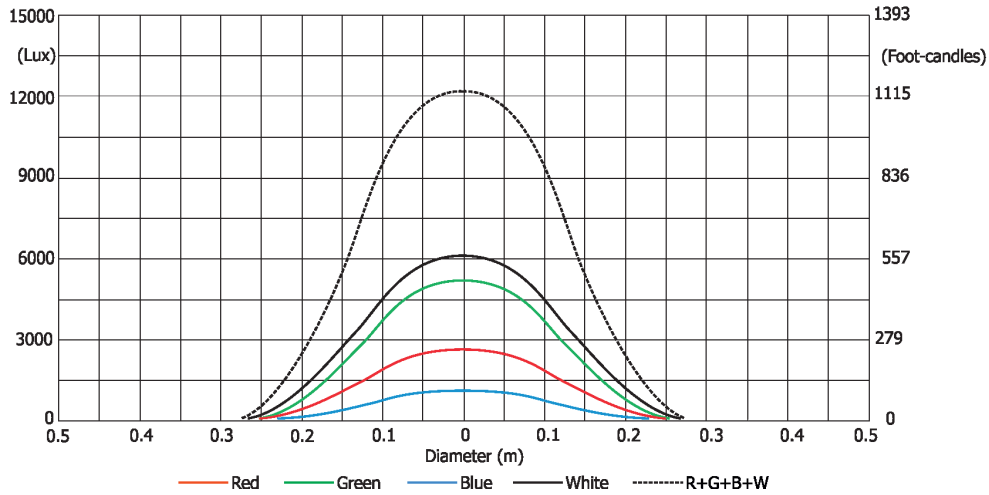

Min. Zoom (with EggCrate)

Total Output: 1143 lumens

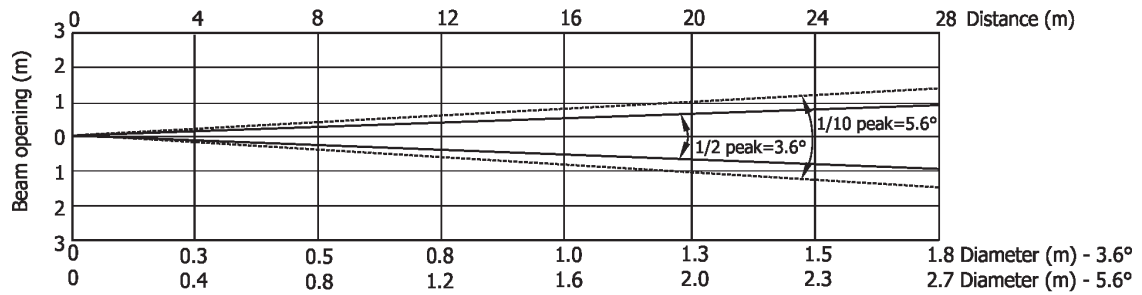

Distance (m)	4	5	8	12	16	20	24	28	
Red	3906/363	2500/232	976/91	434/40	244/23	156/14.5	109/10	80/7.4	Intensity (center) Lux/Footcandles
Green	7438/691	4760/442	1859/173	826/77	464/43	298/28	207/19	152/14	
Blue	1672/155	1070/99	418/39	186/17	105/10	66/6	46/4	34/3	
White	9422/875	6030/560	2355/219	1046/97	588/55	377/35	262/24	192/18	
R+G+B+W	18797/1746	12030/1118	4700/437	2088/194	1174/109	752/70	522/49	384/36	

Illuminance distribution

Distance=5m

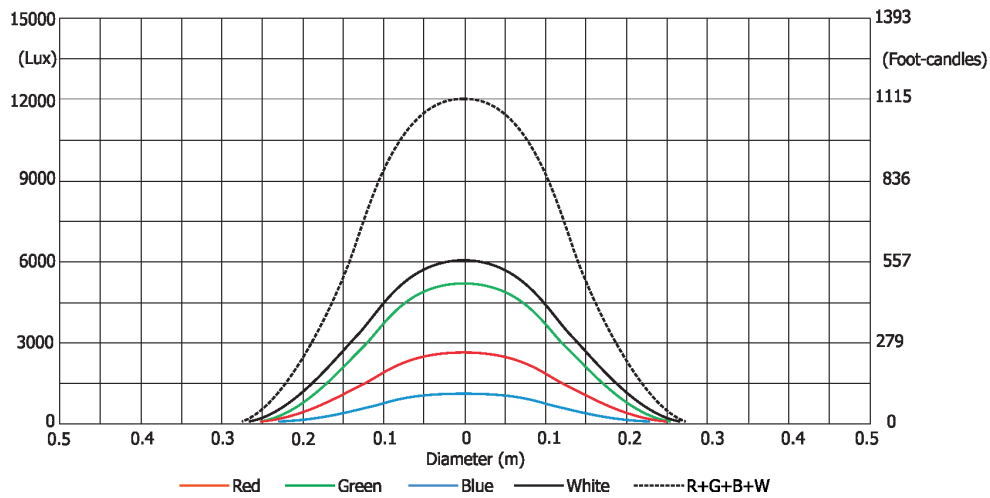

Max. Zoom

Total Output: 2842 lumens

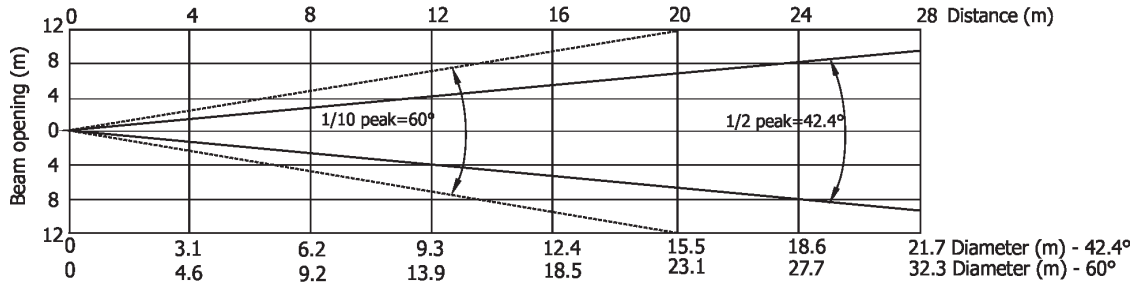

Distance (m)	4	5	8	12	16	20	24	28	
Red	87/5	56/5	22/2	10/0.9	6/0.5	4/0.3	2/0.2	2/0.2	Intensity (center) Lux/Footcandles
Green	168/10	108/10	42/4	19/1.7	11/1	6.8/0.6	5/0.4	3/0.3	
Blue	36/3	23/2	9/0.8	4/0.4	2/0.2	1.4/0.1	1/0.1	0.7/0.1	
White	209/20	134/12.4	52/5	23/2	13/1	8/0.7	6/0.5	4/0.4	
R+G+B+W	417/39	267/25	104/10	46/4	26/2.4	17/1.6	12/1	9/0.8	

Illuminance distribution

Distance=5m

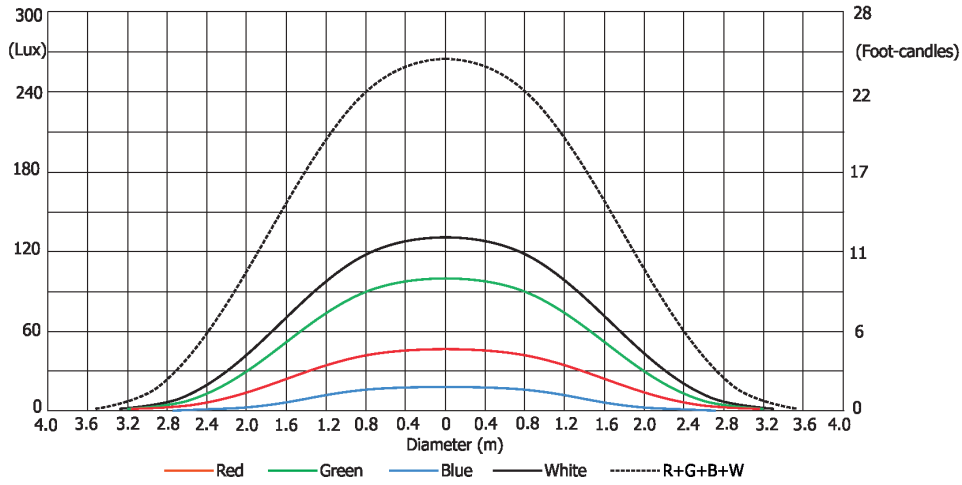

Max. Zoom (with EggCrate)

Total Output: 2614 lumens

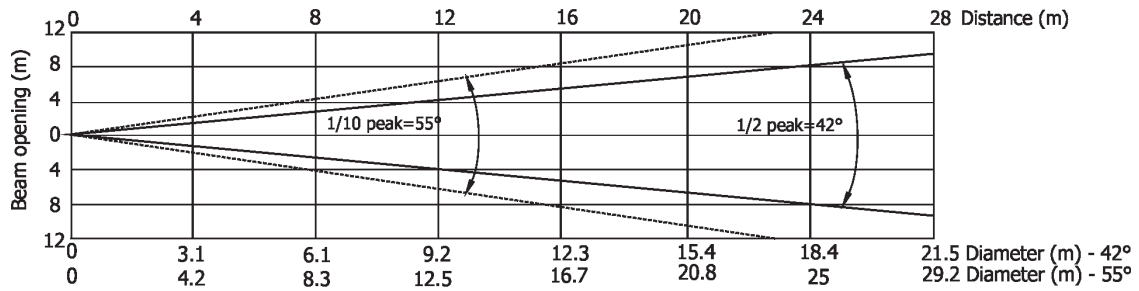

Distance (m)	4	5	8	12	16	20	24	28	
Red	78/7	50/5	20/2	9/0.8	5/0.5	3/3.1	2/0.2	2/0.1	Intensity (center) Lux/Footcandles
Green	163/15	104/10	41/4	18/1.7	10/0.9	7/0.6	5/0.4	3/0.3	
Blue	34/3	22/2	9/0.8	4/0.4	2/0.2	1.4/0.1	1/0.1	0.7/0.1	
White	195/18	125/12	49/5	22/2	12/1	8/0.7	5/0.5	4/0.4	
R+G+B+W	375/35	240/22	94/9	42/4	23/2	15/1.4	10/1	7/0.7	

Illuminance distribution

Distance=5m

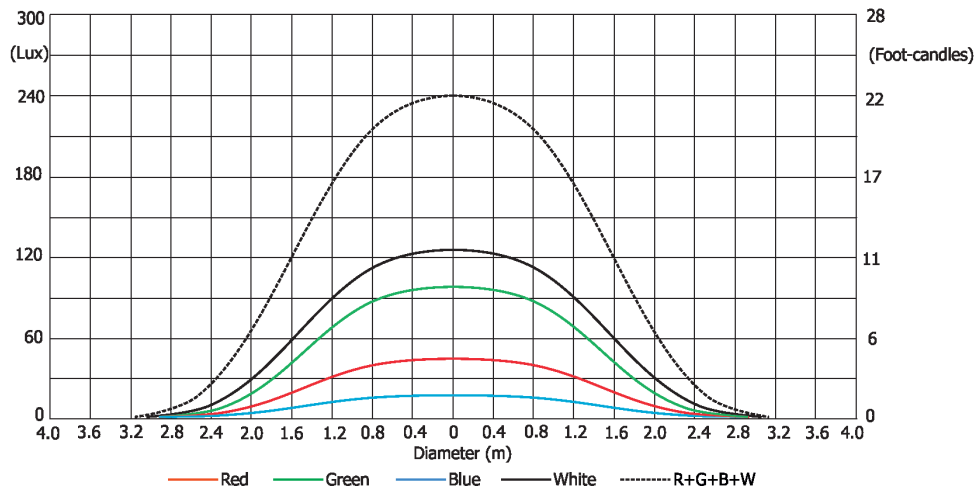

Robin LED Beam 150 with Diffuser 2°

Min. Zoom

Total Output: 1136 lumens

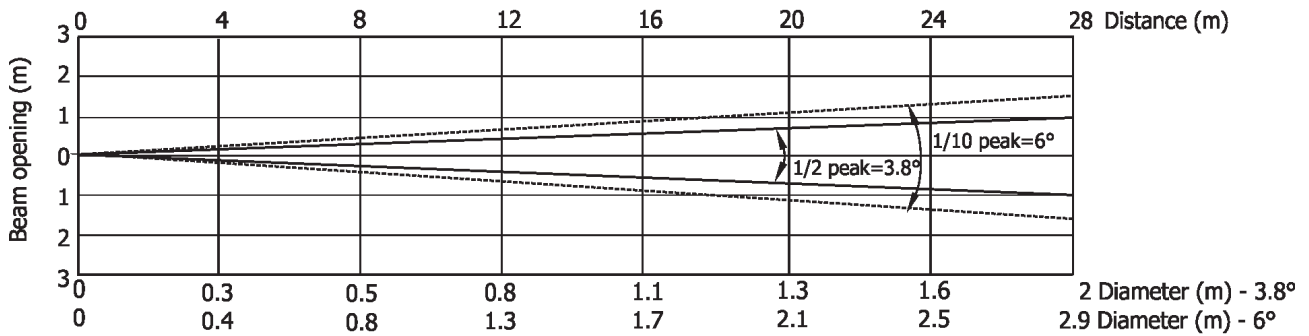

Distance (m)	4	5	8	12	16	20	24	28	
Red	2609/242	1670/155	652/61	290/27	163/15	104/10	73/7	53/5	Intensity (center) Lux/Footcandles
Green	6000/557	3840/357	1500/139	666/62	375/35	240/22	166/16	122/11	
Blue	875/82	560/52	219/20	97/9	55/5	35/3.3	24/2.3	18/1.7	
White	7234/672	4630/430	1809/168	803/75	452/42	289/27	201/19	147/14	
R+G+B+W	12797/1189	8190/761	3200/297	1422/132	800/74	511/48	355/33	261/24	

Illuminance distribution

Distance=5m

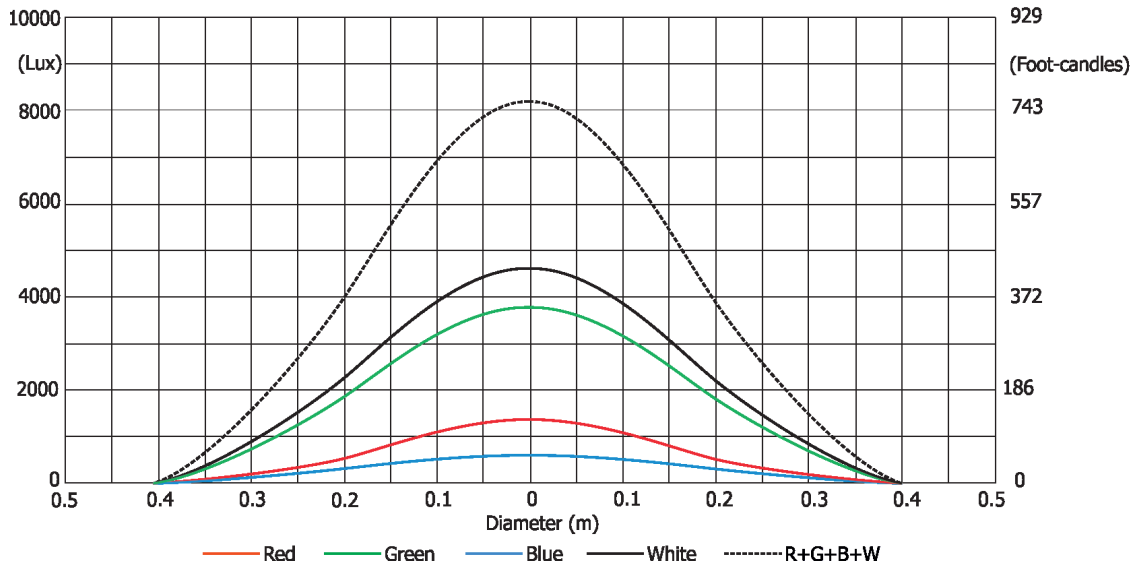

December 18, 2024

Copyright © 2017-2024 Robe Lighting - All rights reserved

All Specifications subject to change without notice

Made in ROBE Lighting s.r.o., Palackého 416, 757 01 Valašské Meziříčí, Czech Republic

Max. Zoom

Total Output: 2288 lumens

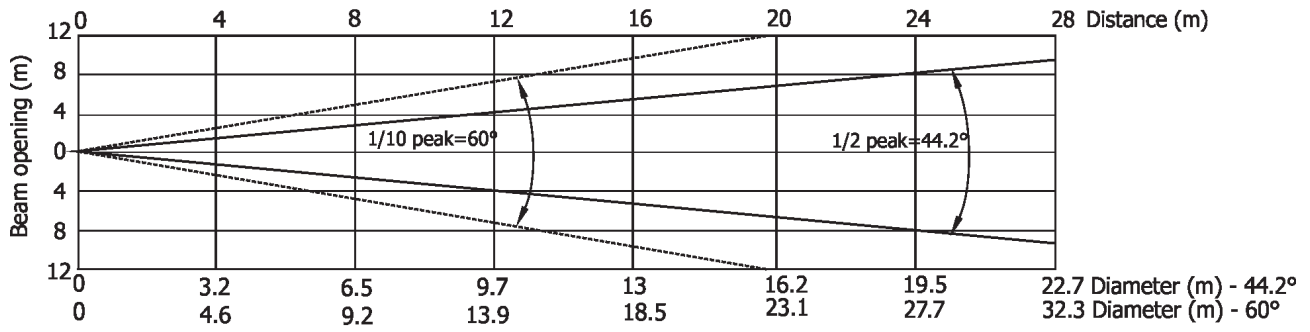

Distance (m)	4	5	8	12	16	20	24	28	
Red	73/6.8	47/4.4	18/1.7	8/0.8	5/0.4	3/0.3	2/0.2	1.5/0.1	Intensity (center) Lux/Footcandles
Green	148/14	95/9	37/3.4	17/1.5	9/1	6/0.6	4/0.4	3/0.3	
Blue	20/2	13/1.2	5/0.5	2.3/0.2	1.3/0.1	0.8/0.1	0.6/0.1	0.4/0.08	
White	181/17	116/11	45/4.2	20/1.9	11.3/1.1	7/0.7	5/0.5	4/0.3	
R+G+B+W	333/31	215/20	84/8	37/3.5	21/2	13/1.2	9/1	7/0.6	

Illuminance distribution

Distance=5m

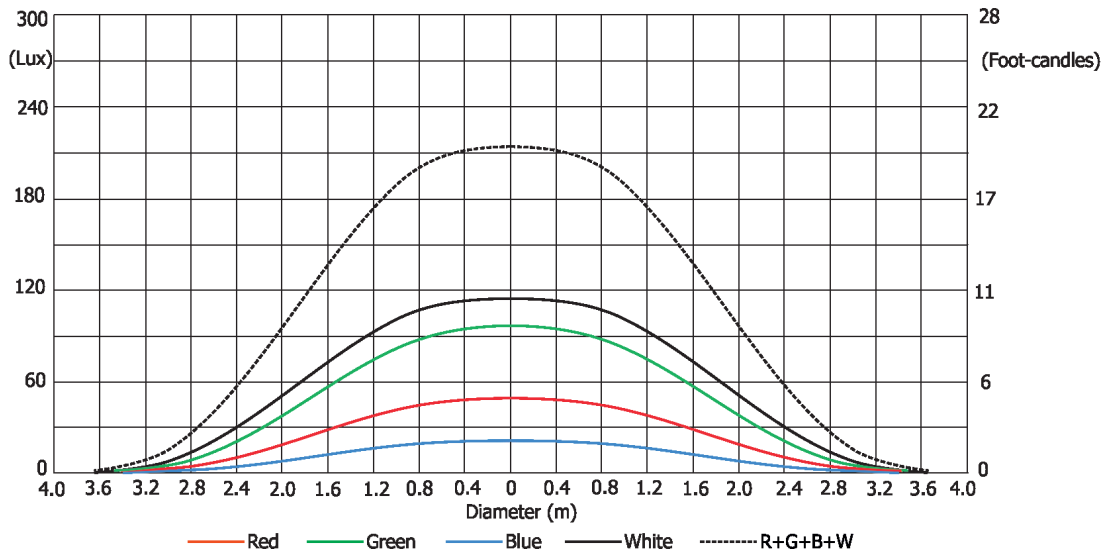

11. ChangeLog

This section summarizes all types of changes in the user manual.

V. of the manual	Date of issue	Description of changes
1.1	05/05/2017	EggCrate installation added, DMX protocol ver.1.1
1.2	07/06/2017	Quiet mode for fan in menu Personality, DMX protocol ver. 1.2
1.3	18/01/2018	Optional accessories changed, Dmx protocol ver. 1.3,diffuser 2°installation
1.4	27/04/2018	DMX protocol ver.1.4
1.5	15/04/2019	DMX protocol ver. 1.5
1.6	18/09/2019	DMX protocol ver. 1.6
1.7	12/11/2019	Description of lenses cleaning added
1.8	15/10/2019	Added information about foggy lens array
1.9	24/02/2022	Q- version added
2.0	01/04/2022	Safety instructions changed
2.1	06/01/2025	Ceiling mount kit added

DMX protocol

Robin LEDdBeam 150/LEDBeam 150 FW/LEDBeam 150Q/LEDBeam 150 FWQ - DMX protocol				
Version: 1.7 Mode 1-Standard 16-bit, Mode 2 -Reduced 8-bit				
Mode/channel		DMX Value	Function	Type of control
1	2			
1	1		Pan (8 bit)	
		0 - 255	Pan movement by 450° (128=default)	proportional
2	2		Pan Fine (16 bit)	
		0 - 255	Fine control of pan movement (0=default)	proportional
3	3		Tilt (8 bit)	
		0 - 255	Tilt movement by 228° (128=default)	proportional
4	4		Tilt fine (16 bit)	
		0 - 255	Fine control of tilt movement (0=default)	proportional
5	5		Pan/Tilt speed , Pan/Tilt time	
		0	Standard mode (0=default)	step
		1	Max. Speed Mode	step
			Pan/Tilt speed mode	
		2 - 255	Speed from max. to min.	proportional
			Pan/Tilt time mode	
		2 - 255	Time from 0.2 sec. to 25.5 sec.	proportional
6	6		Power/Special functions	
		0 -19	Reserved (0=default)	
			<i>To activate following functions, stop in DMX value for at least 3 s and shutter must be closed at least 3 sec. („Shutter,Strobe“ channel 20/15 must be at range: 0-31 DMX). Corresponding menu items are temporarily overridden.</i>	
		20-24	Display ON	step
		25-29	Display OFF	step
		30-34	RGBW colour mixing mode	step
		35-39	CMY colour mixing mode	step
		40-44	Pan/Tilt speed mode	step
		45 - 49	Pan/Tilt time mode	step
		50 -54	Blackout while pan/tilt moving	step
		55 -59	Disabled blackout while pan/tilt moving	step
		60 - 64	Dimmer curve - square law	step
		65 - 69	Dimmer curve - linear	step
		70 - 74	Fans mode: Auto	step
		75 - 79	Fans mode: High	step
		80-84	White point 8000K ON	step
		85-89	White point 8000K OFF	step
		90-94	Fans mode: Quiet	step
		95 -129	Reserved	
			<i>To activate following functions, stop in DMX value for at least 3 seconds. Corresponding menu items are temporarily overridden.</i>	
		130 - 139	Reserved	
		140 - 149	Pan/Tilt reset	step
		150 - 159	Zoom reset	step
		160 - 169	Reserved	step
			<i>Tungsten effect simulation for whites 2700K and 3200K</i>	
		170-171	Tungsten effect simulation (750W) On	step
		172-173	Tungsten effect simulation (1000W) On	step

DMX protocol

Mode/channel		DMX Value	Function	Type of control
1	2			
		174-175	Tungsten effect simulation (1200W) On	step
		176-177	Tungsten effect simulation (2000W) On	step
		178-179	Tungsten effect simulation (2500W) On	step
		180-181	Tungsten effect simulation Off	step
		182-184	Reserved	
		185	PWM output frequency of LEDS: Standard (300Hz)**	step
		186	PWM output frequency of LEDS: High (600Hz)**	step
			** You can adjust selected frequency in 6 steps Up or Down around selected frequency - see table below . Default value of PWM frequency set in the fixture is Standard.	
		187	LED Frequency (step -6)	step
		188	LED Frequency (step -5)	step
		189	LED Frequency (step -4)	step
		190	LED Frequency (step -3)	step
		191	LED Frequency (step -2)	step
		192	LED Frequency (step -1)	step
		193	LED Frequency (Standard or High)	step
		194	LED Frequency (step +1)	step
		195	LED Frequency (step +2)	step
		196	LED Frequency (step +3)	step
		197	LED Frequency (step +4)	step
		198	LED Frequency (step +5)	step
		199	LED Frequency (step +6)	step
		200 - 209	Total fixture reset	step
		210 - 218	Reserved	
			The following RoboSpot related commands are only applicable when the RoboSpot is connected:	
		219 - 220	RoboSpot enabled	step
		221 - 222	RoboSpot disabled - except handle faders and pan/tilt	step
		223 - 224	RoboSpot fully disabled	step
		225 - 255	Reserved	
7	7		Virtual colour wheel	
		0	No function (0=default)	step
		1-2	Filter 4 (Medium Bastard Amber)	step
		3-4	Filter 25 (Sunset Red)	step
		5-6	Filter 19 (Fire)	step
		7-8	Filter 26 (Bright Red)	step
		9-10	Filter 58 (Lavender)	step
		11-12	Filter 68 (Sky Blue)	step
		13-14	Filter 36 (Medium Pink)	step
		15-16	Filter 89 (Moss Green)	step
		17-18	Filter 88 (Lime Green)	step
		19-20	Filter 90 (Dark Yellow Green)	step
		21-22	Filter 49 (Medium Purple)	step
		23-24	Filter 52 (Light Lavender)	step
		25-26	Filter 102 (Light Amber)	step
		27-28	Filter 103 (Straw)	step
		29-30	Filter 140 (Summer Blue)	step
		31-32	Filter 124 (Dark Green)	step
		33-34	Filter 106 (Primary Red)	step
		35-36	Filter 111 (Dark Pink)	step

DMX protocol

Mode/channel		DMX Value	Function	Type of control
1	2			
		37-38	Filter 115 (Peacock Blue)	step
		39-40	Filter 126 (Mauve)	step
		41-42	Filter 117 (Steel Blue)	step
		43-44	Filter 118 (Light Blue)	step
		45-46	Filter 122 (Fern Green)	step
		47-48	Filter 182 (Light Red)	step
		49-50	Filter 121 (Filter Green)	step
		51-52	Filter 128 (Bright Pink)	step
		53-54	Filter 131 (Marine Blue)	step
		55-56	Filter 132 (Medium Blue)	step
		57-58	Filter 134 (Golden Amber)	step
		59-60	Filter 135 (Deep Golden Amber)	step
		61-62	Filter 136 (Pale Lavender)	step
		63-64	Filter 137 (Special Lavender)	step
		65-66	Filter 138 (Pale Green)	step
		67-68	Filter 798 (Chrysalis Pink)	step
		69-70	Filter 141 (Bright Blue)	step
		71-72	Filter 147 (Apricot)	step
		73-74	Filter 148 (Bright Rose)	step
		75-76	Filter 152 (Pale Gold)	step
		77-78	Filter 154 (Pale Rose)	step
		79-80	Filter 157 (Pink)	step
		81-82	Filter 143 (Pale Navy Blue)	step
		83-84	Filter 162 (Bastard Amber)	step
		85-86	Filter 164 (Flame Red)	step
		87-88	Filter 165 (Daylight Blue)	step
		89-90	Filter 169 (Lilac Tint)	step
		91-92	Filter 170 (Deep Lavender)	step
		93-94	Filter 172 (Lagoon Blue)	step
		95-96	Filter 194 (Surprise Pink)	step
		97-98	Filter 180 (Dark Lavender)	step
		99-100	Filter 181 (Congo Blue)	step
		101-102	Filter 197 (Alice Blue)	step
		103-104	Filter 201 (Full C.T. Blue)	step
		105-106	Filter 202 (Half C.T. Blue)	step
		107-108	Filter 203 (Quarter C.T. Blue)	step
		109-110	Filter 204 (Full C.T. Orange)	step
		111-112	Filter 219 (Fluorescent Green)	step
		113-114	Filter 206 (Quarter C.T. Orange)	step
		115-116	Filter 247 (Filter Minus Green)	step
		117-118	Filter 248 (Half Minus Green)	step
		119-120	Filter 281 (Three Quarter C.T. Blue)	step
		121-122	Filter 285 (Three Quarter C.T. Orange)	step
		123-124	Filter 352 (Glacier Blue)	step
		125-126	Filter 353 (Lighter Blue)	step
		127-128	Filter 507 (Madge)	step
		129-130	Filter 778 (Millennium Gold)	step
		131-132	Filter 793 (Vanity Fair)	step
		133-235	Raw DMX	proportional

DMX protocol

Mode/channel		DMX Value	Function	Type of control
1	2			
		236-245	Rainbow effect (with fade time) from slow-> fast	proportional
		246-255	Rainbow effect (without fade time) from slow-> fast	proportional
8	8		Red/Cyan (8 bit)*	
		0 - 255	Colour saturation control - coarse 0-100% (255=default)	proportional
9	*		Red/Cyan (16bit)*	
		0 - 255	Colour saturation control - fine (255=default)	proportional
10	9		Green/Magenta (8 bit) *	
		0 - 255	Colour saturation control - coarse 0-100% (255=default)	proportional
11	*		Green/Magenta (16bit) *	
		0 - 255	Colour saturation control - fine (255=default)	proportional
12	10		Blue/Yellow (8 bit) *	
		0 - 255	Colour saturation control - coarse 0-100% (255=default)	proportional
13	*		Blue/ Yellow (16bit) *	
		0 - 255	Colour saturation control - fine (255=default)	proportional
14	11		White (8 bit)	
			<i>If RGBW mode is selected:</i>	
		0-255	Colour saturation control - coarse 0-100% (255=default)	proportional
			<i>If CMY mode is selected:</i>	
		0 - 255	No function	
15	*		White (16 bit)	
		0 - 255	Colour saturation control - fine (255=default)	proportional
16	12		CTC	
			<i>If function "White Point 8000K" is ON</i>	
		0-255	Col. temperature correction from 8000K to 2700K -for whites only (0=8000K, 64=5600K, 128=4200K, 192=3200K, 255=2700K)	proportional
			To get colour temperatures stated above, RGBW channels have to be set at the same value e.g. 255DMX (0=default)	
			(To activate Tungsten effect at 2700K and 3200K , set DMX value at "Power/Special functions" channel)	
			<i>If function "White Point 8000K" is OFF</i>	
		0-255	Colour temperature correction for from cool white to 2700K	proportional
17	13		Colour Mix control	
			<i>Defines relation between colour channels</i>	
			"Virtual" = Virtual Colours (Virtual Colour Wheel)	
			"Colour mix" = Colour channels (RGBW/CMY)	
		0-9	Virtual colors ("Virtual" has priority)	step
		10-19	Maximum mode (highest values have priority)	step
		20-29	Minimum mode (lowest values have priority)	step
		30-39	Multiply mode (multiply Virtual and Colour Mix)	step
		40-49	Addition mode (Virtual + Colour mix) (45=default)	step
		50-59	Subtraction mode (Virtual – Colour mix)	step
		60-69	Inverted Subtraction mode (Virtual – Colour mix)	step
		70-128	Reserved	
		129	Virtual colors (virtual has priority)	step
		130-254	Crossfade (crossfade between Virtual and Colour mix)	proportional
		255	Colour channels ("Colour mix" has priority)	step
18	14		Zoom	
		0-255	Zoom from max. to min.beam angle (128=default)	proportional
19	*		Zoom - fine	
		0-255	Fine zooming (0=default)	proportional

DMX protocol

Mode/channel		DMX Value	Function	Type of control
1	2			
20	15		Shutter/ strobe	
		0 - 31	Shutter closed	step
		32 - 63	Shutter open (32=default)	step
		64 - 95	Strobe-effect from slow to fast	proportional
		96 - 127	Shutter open	step
		128 - 143	Opening pulse in sequences from slow to fast	proportional
		144 - 159	Closing pulse in sequences from fast to slow	proportional
		160 - 191	Shutter open	step
		192 - 223	Random strobe-effect from slow to fast	proportional
		224 - 255	Shutter open	step
21	16		Dimmer intensity (8 bit)	
		0 - 255	Dimmer intensity from 0% to 100% (0=default)	proportional
22	*		Dimmer intensity - fine (16 bit)	
		0 - 255	Fine dimming (0=default)	proportional
*Select RGB or CMY mixing mode on channel "Power/Special functions" .				
Copyright © 2017-2022 Robe Lighting s.r.o. - All rights reserved				
All Specifications subject to change without notice				

Colours on Virtual Colour Wheel				
Colour name	Red (DMX)	Green (DMX)	Blue (DMX)	White (DMX)
Filter 4 (Medium Bastard Amber)	255	118	0	109
Filter 25 (Sunset Red)	255	47	0	3
Filter 19 (Fire)	255	13	0	0
Filter 26 (Bright Red)	255	0	0	0
Filter 58 (Lavender)	117	0	97	155
Filter 68 (Sky Blue)	31	219	105	6
Filter 36 (Medium Pink)	255	74	8	24
Filter 89 (Moss Green)	69	245	0	3
Filter 88 (Lime Green)	187	226	0	0
Filter 90 (Dark Yellow Green)	2	255	0	0
Filter 49 (Medium Purple)	255	0	27	0
Filter 52 (Light Lavender)	232	88	6	166
Filter 102 (Light Amber)	223	164	0	0
Filter 103 (Straw)	191	144	0	28
Filter 140 (Summer Blue)	0	149	3	220
Filter 124 (Dark Green)	29	255	0	12
Filter 106 (Primary Red)	242	1	1	0
Filter 111 (Dark Pink)	255	67	11	49
Filter 115 (Peacock Blue)	0	255	29	43
Filter 126 (Mauve)	255	0	39	0
Filter 117 (Steel Blue)	179	255	14	197
Filter 118 (Light Blue)	0	255	76	30
Filter 122 (Fern Green)	98	255	0	4
Filter 182 (Light Red)	255	16	2	0
Filter 121 (Filter Green)	165	255	0	0
Filter 128 (Bright Pink)	255	0	13	32
Filter 131 (Marine Blue)	73	245	27	30
Filter 132 (Medium Blue)	0	230	120	0
Filter 134 (Golden Amber)	166	83	0	0
Filter 135 (Deep Golden Amber)	255	50	0	0
Filter 136 (Pale Lavender)	140	101	25	40
Filter 137 (Special Lavender)	110	60	45	102
Filter 138 (Pale Green)	241	255	4	48
Filter 798 (Chrysalis Pink)	49	0	98	26
Filter 141 (Bright Blue)	0	225	62	5
Filter 147 (Apricot)	190	107	0	15
Filter 148 (Bright Rose)	255	3	0	37
Filter 152 (Pale Gold)	179	119	0	39
Filter 154 (Pale Rose)	214	118	0	48
Filter 157 (Pink)	255	56	5	43
Filter 143 (Pale Navy Blue)	0	193	67	148
Filter 162 (Bastard Amber)	211	153	6	36
Filter 164 (Flame Red)	255	27	0	4
Filter 165 (Daylight Blue)	23	236	93	81
Filter 169 (Lilac Tint)	185	123	0	109
Filter 170 (Deep Lavender)	235	123	41	37
Filter 172 (Lagoon Blue)	0	255	63	5

Colour name	Red (DMX)	Green (DMX)	Blue (DMX)	White (DMX)
Filter 194 (Surprise Pink)	110	0	21	255
Filter 180 (Dark Lavender)	136	43	181	120
Filter 181 (Congo Blue)	24	0	255	9
Filter 197 (Alice Blue)	79	193	154	36
Filter 201 (Full C.T. Blue)	153	223	66	156
Filter 202 (Half C.T. Blue)	255	248	34	116
Filter 203 (Quarter C.T. Blue)	245	213	14	147
Filter 204 (Full C.T. Orange)	230	131	3	3
Filter 219 (Fluorescent Green)	99	148	16	50
Filter 206 (Quarter C.T. Orange)	199	152	0	60
Filter 247 (Filter Minus Green)	255	79	0	187
Filter 248 (Half Minus Green)	255	138	0	112
Filter 281 (Three Quarter C.T. Blue)	225	255	99	189
Filter 285 (Three Quarter C.T. Orange)	181	121	0	15
Filter 352 (Glacier Blue)	0	161	49	90
Filter 353 (Lighter Blue)	0	115	21	97
Filter 507 (Madge)	255	31	0	0
Filter 778 (Millennium Gold)	255	65	0	0
Filter 793 (Vanity Fair)	255	0	13	16